

HSK一体型

槽加工

侧面加工

[标准型]



● 型号说明

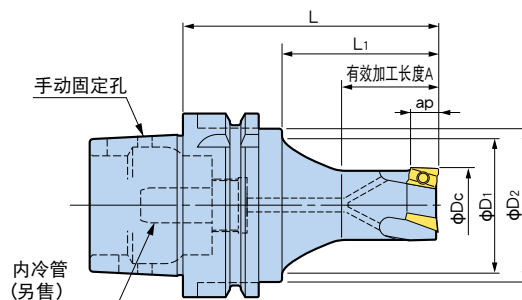
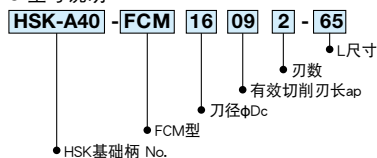

A 型 (DIN69893-1) (ISO12164)

刀径 φDc	型 号	有效切削刃长 ap	φD ₁	φD ₂	L	L ₁	有效加工长度 A	刃数	对应刀片型号	质量 (kg)
16	HSK-A40-FCM16092- 65	9	25	34	65	37	23	2	ARG1609□□	0.3
20	-FCM20093- 65						28	3	ARG2009□□	0.3
25	-FCM25093- 65						35		ARG2509□□	0.4
32	-FCM32113- 65						30.8		ARG3211□□	0.5
40	-FCM40114- 65						11	—	—	—
50	-FCM50115- 65	—	—	—	—	—	5	ARG4011□□	0.7	
16	HSK-A50-FCM16092- 75	9	32	42	75	41	23	2	ARG1609□□	0.6
20	-FCM20093- 75						28	3	ARG2009□□	0.6
25	-FCM25093- 75						33		ARG2509□□	0.6
32	-FCM32113- 75						33.8		ARG3211□□	0.7
40	-FCM40114- 75						11	—	—	—
50	-FCM50115- 75	—	—	—	—	—	5	ARG4011□□	1.0	
16	HSK-A63-FCM16092- 85	9	46	53	85	51	23	2	ARG1609□□	0.9
	-105				105	71	30			1.0
	-120				120	86	25			1.1
	-150				150	116	25			1.3
20	-FCM20093- 85	9	46	53	85	51	28	3	ARG2009□□	1.0
	-105				105	71	35			1.1
	-120				120	86	30			1.2
	-150				150	116	30			1.4
25	-FCM25093- 85	9	46	53	85	51	33	3	ARG2509□□	1.0
	-120				120	86	45			1.2
	-135				135	101	40			1.3
	-165				165	131	40			1.5
32	-FCM32113- 85	11	46	53	85	51	38	3	ARG3211□□	1.1
	-120				120	86	60			1.3
	-135				135	101	50			1.4
	-165				165	131	40			1.7
40	-FCM40114- 85	11	46	53	85	51	43	4	ARG4011□□	1.3
	120				120	86	65			1.5
	135				135	101	60			1.7
	165				165	131	50			2.1
50	-FCM50115- 70	11	—	53	70	28	28	5	ARG4011□□	1.3
	-120				120	78	78			1.9
	-135				135	93	93			2.2
	-165				165	123	123			2.8

1. 附带扳手，不附带刀片，请另行订购。
2. 不附带内冷管，请另行订购。C63

关于刀片请参阅**114**

关于切削条件请参阅**115**

[加长型]

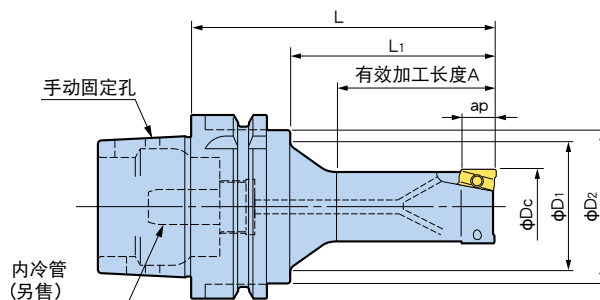

A 型 (DIN69893-1) (ISO12164)

刀径 φDc	型 号	有效切削刃长 ap	φD ₁	φD ₂	L	L ₁	有效加工长度 A	刃数	对应刀片型号	质量 (kg)
16	HSK-A63-FCM16092L- 85	9	46	53	85	51	40	2	ARG1609□□	0.9
	-120				120	86	45			1.0
20	-FCM20092L-105	9	46	53	105	71	50	2	ARG2009□□	1.1
	-120				120	86	60			1.2
25	-FCM25092L-105	9	46	53	105	71	55	2	ARG2509□□	1.1
	-120				120	86	65			1.2
32	-FCM32112L-120	11	46	53	120	86	70	2	ARG3211□□	1.3
	-135				135	101	80			1.4

1. 附带扳手，不附带刀片，请另行订购。
2. 不附带内冷管，请另行订购。C63

关于刀片请参阅I14

关于切削条件请参阅I15

[标准型]



● 型号说明

HSK-E25 - **FCM** **16** **09** **2** - **45**
 ● HSK-E基础柄 No. ● FCM型
 ● 刀径φ16 ● 有效切削刃长ap
 ● 刃数 ● L尺寸

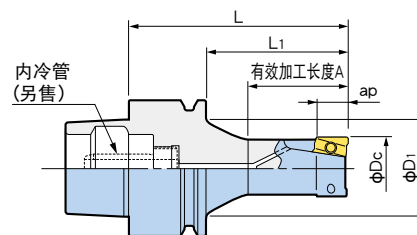

E 型 (DIN69893-5)

刀径 φDc	型 号	有效切削刃长 ap	φD ₁	L	L ₁	有效加工长度 A	刃数	对应刀片型号	质量 (kg)
16	HSK-E25-FCM16092-45	9	19	45	35	23	2	ARG1609□□	0.17
	-E32-FCM16092-55			55	35	23			0.20
	-E40-FCM16092-65			65	45	28			0.45

1. 附带扳手，不附带刀片，请另行订购。
2. 不附带内冷管，请另行订购。C63

关于刀片请参阅I14

关于切削条件请参阅I15

请注意

由于HSK-E型刀柄没有传动槽，所以当切削力大于机械主轴的夹持力时，会导致刀柄在主轴内滑动，并造成主轴内壁损伤。因此，使用时请从极低切削条件开始，根据加工情况逐渐提高切削量，并找到最佳切削条件。